

Autodesk®  
for the Consumer Products Industry

Experience It Before It's Real



Autodesk®

# Get Your Products to Market Easier and Faster

Facilitate innovation and accelerate new product development with the Autodesk solution for Digital Prototyping.

## Industry Challenges

Consumer product manufacturers are facing unprecedented challenges in a fast-paced and increasingly competitive environment. Intense competition in the global market is driving manufacturers to bring products to market quicker and with more cost control than ever before. Product differentiation has become increasingly important as consumer products companies are recognizing that aesthetic design and new product innovations are major drivers for revenue. Transforming these great concepts from ideas to reality requires a smooth transition from design to manufacturing. Globally distributed product development teams and supply chains increase the complexity of effective collaboration needed to drive more efficient product development and production processes. Additionally, consumer product manufacturers are challenged with enhancing their brand presence in the market through developing closer customer relationships and strengthening brand loyalty.



Image courtesy of Humanscale



Images courtesy of Genesis-design GmbH

### Strategies for Success

Succeeding in this market requires an intense focus on eliminating inefficiencies throughout the development process from initial concept development to final manufacturing and post-sales support. Design and development teams need the ability to work together in exploring ideas early in the process and to communicate the designs with internal stakeholders and customers. To drive product differentiating through innovation, industrial designers, engineers and manufacturers must be able to work harmoniously together. This allows these multiple disciplines to communicate and collaborate throughout the development process, without recreating data to meet their needs.

The ability to design, visualize, and simulate a product from the earliest concept phase is a vital to avoiding design errors that may not appear until the physical prototyping stage. As competition intensifies regarding new product introductions, timing of product launch is just as critical as the design itself; therefore companies need to be able to create go-to-market materials in parallel with the product development process. This provides consumer product companies the opportunity to develop materials that promote customer preference and reinforce brand loyalty without creating a delay in time-to-market.

### The Autodesk Solution for Digital Prototyping

The Autodesk solution for Digital Prototyping enables workgroups to create a single digital model that can be used in every stage of production, bridging the gaps that typically exist between conceptual design, engineering, and manufacturing teams. This single digital model enables the simulation of the complete product. And gives designers and engineers the ability to better design, visualize, and simulate their designs before producing a physical prototype, in turn helping projects get to market faster with greater product innovation. The Autodesk approach to Digital Prototyping is unique in that it is attainable, scalable, and cost effective, allowing consumer product manufacturers to realize benefits with minimal disruption to existing workflows. Digital Prototyping provides a straightforward path to creating and maintaining a single digital model in a multidisciplinary design and engineering environment.

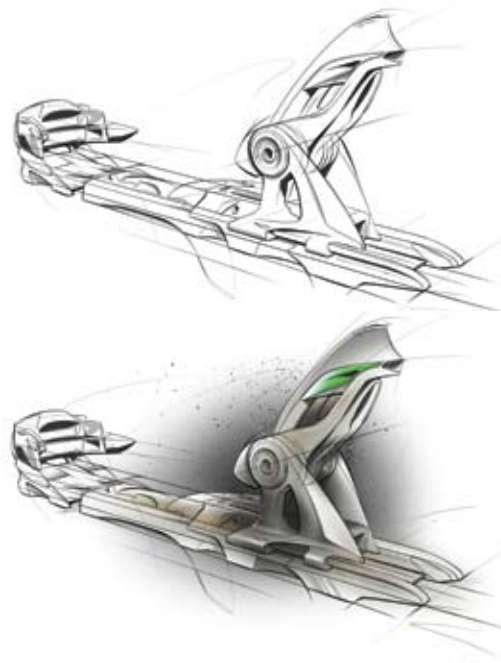

### Common challenges faced by consumer product companies:

- Creating product differentiation
- Intense competition drives shorter development cycles and lower costs
- Demand for growth forces process and manufacturing efficiencies
- Building and maintaining strong brand presence and loyalty
- Product performance issues are discovered late in the product development cycle
- Communication with geographically dispersed development teams
- Disconnected processes between conceptual design, engineering, and manufacturing



### Conceptual Design

Autodesk's integrated design tools help to create the initial digital model from early sketches through design modeling, visualization and decision-making and final technical surfacing. These tools enable designers to work closely with engineers on a single digital model to balance aesthetic and functional requirements while accelerating innovation and development. Using Autodesk products, consumer product companies can develop cutting-edge concepts; optimize their manufacturability; and efficiently share information with engineering, downstream users, customers, and suppliers.

With market-leading industrial design tools from Autodesk you can:

- Work digitally from project start
- Create highly realistic representations of your product for design, marketing, and customer reviews, before a physical prototype has ever been created
- Clearly communicate design intent with a meaningful design model, using a common file format



Image courtesy of Indesit Company

The Autodesk solution for Digital Prototyping offers tools that span the design-to-manufacturing process, from initial concept to sourcing and supplier collaboration:

- **Concept exploration**— Freeing designers' creativity with a comprehensive set of award-winning industrial design products that lets them sketch, annotate, and present visual ideas.
- **Design modeling**— Enabling industrial designers to work with best-in-class industrial design tools from the start of a project, letting them capture their ideas digitally from initial sketches through 3D concept models.
- **Styling and surfacing**— Giving stylists and designers a creative, iterative process to develop design concepts.
- **Visualization and communication**— Making it easier for designers to bring ideas to life and communicate ideas.

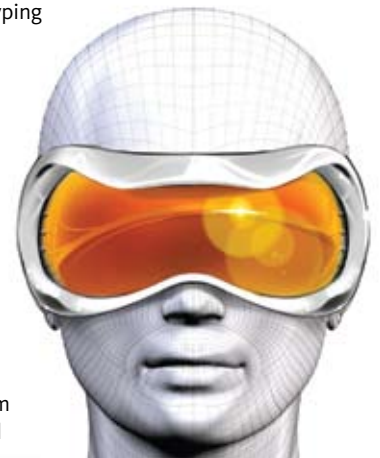

Autodesk offers a comprehensive set of industrial design products which cover all aspects of the conceptual design, Class A surfacing, visualization, and collaboration process.

- Autodesk® Alias family of products (previously known as Autodesk® AliasStudio®) is the industry standard for conceptual design in 2D and 3D from ideation sketching through concept modeling, surfacing and design communication.
- Autodesk® Sketchbook® Pro provides best-in-class digital sketching capabilities for up front design using a digitized pen tablet and tablet PC.
- Autodesk® Showcase® provides a solution for design visualization and communication by accelerating design and marketing decision making about your designs. It lets your designers visualize, present, and select design options digitally by delivering accurate, realistic imagery created from 3D design data.
- Autodesk industrial design products provide a wide range of data exchange and engineering collaboration workflows with product development tools, including Autodesk® Inventor® and many other 3D CAD tools.

## Engineering

Autodesk addresses the needs of consumer product manufacturers by putting scalable, attainable, and cost-effective desktop technology in the hands of global engineering teams.

The Autodesk® solution for Digital Prototyping in the engineering workflow enables:

- **Packaging design**—Reuse of concept data to create 3D models and creatively combine industrial design and detailed engineering.
- **Simulation and analysis**—Minimizing the need for physical prototypes, let users optimize and validate design and engineering data as they work, and reduce costly engineering changes.
- **Supplier collaboration**—Improving collaboration between extended team members during critical design and engineering efforts, and speed reviews.
- **Data management**—Providing design and development teams with the tools to produce designs that are complete, accurate, approved, and released to manufacturing in a timely and effective manner.

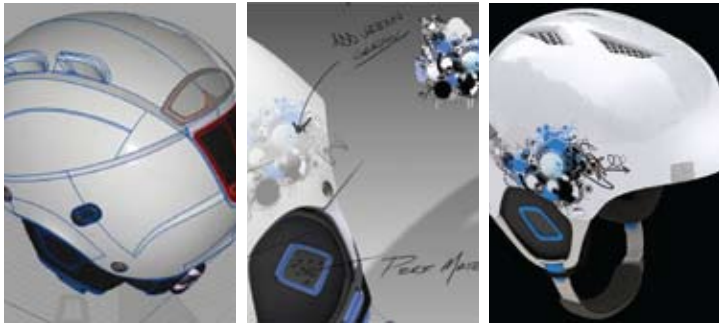

Images courtesy of City Electric

With Autodesk® Inventor® software, the foundation of the Autodesk® solution for Digital Prototyping, you can easily and quickly validate the form, fit, and function of a design under real-world conditions before it is built.

The smooth, bidirectional interoperability between Autodesk Inventor software and AutoCAD Electrical allows you to easily incorporate your electrical controls designs into 2D or 3D mechanical designs, so electrical and mechanical teams can work collaboratively. Autodesk Inventor provides capabilities ranging from complete parametric 3D modeling to dynamic simulation and powerful analysis tools. Modeling capabilities extend to multi-disciplinary needs such as 3D routing of cable harnesses, hoses, pipes, and tubes. Dynamic simulation capabilities represent the entire model and are tightly coupled to analysis tools to provide a powerful desktop solution.



Autodesk Inventor includes a wide range of native translators to incorporate and share data in a variety of CAD formats, which is often needed when dealing with remote manufacturing partners. Inventor also shares data, including geometry and materials, with Alias Design and Showcase to provide an effective way to leverage the single digital model from conceptual design through engineering.

The Autodesk Moldflow® family of products provides the designer with simulation tools to predict the manufacturability of injection molded components during the design process, avoiding potential issues before the design is frozen and tools are fabricated. Autodesk Inventor provides the only associative sharing of data with AutoCAD® and AutoCAD® Mechanical, and includes the ability to generate DWF™ data from the original model, improving the ability to collaborate with internal teams and external partners that use AutoCAD.

Autodesk enhances internal and external collaboration by better sharing and managing design data with products like Autodesk® Vault (formerly known as Autodesk® Productstream®) and Autodesk Design Review. Autodesk Design Review software is the most widely used design review and markup software in the world with over 20 million downloads to date. Autodesk Vault enables the effective reuse of product design data and the ability to leverage prior design analyses, freeing design teams to focus on true product innovation.



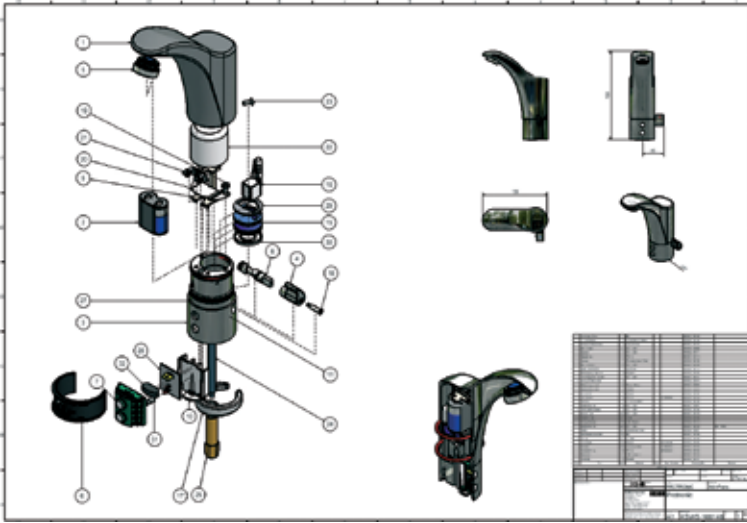

Images courtesy of Franke

## Manufacturing

Getting products to market quickly is critical for consumer products manufacturers. With shrinking market windows and increased global competition, synchronizing product design with manufacturing processes is vital in order to deliver high-quality products faster.

Autodesk tools facilitate the integration of product design with tooling, equipment, and manufacturing plant layout capabilities.

The Autodesk solution for Digital Prototyping supports the key processes of the manufacturing phase for the consumer products industry:

- **Release processes**—Automating the release management process by managing engineering changes and bills of materials (BOMs).
- **Supply chain management**—Improving communication and collaboration between extended teams to enhance productivity and reduce errors.
- **Tooling**—Building individual parts and subassemblies to define complete tooling structures and verify that the product can be built.
- **Production and plant layout**—Combining product design and engineering data with manufacturing process information to coordinate and streamline manufacturing, production, and assembly operations.
- **Data management**—Managing data for a single digital model from inception through manufacturing and beyond.



Image courtesy of CALSYNC

Autodesk® Inventor® and AutoCAD® Mechanical provide the ability to associatively work with 3D tool, jig, and fixture designs and 2D equipment layouts while incorporating 3D product design data from Inventor or other CAD solutions. It also provides the ability to simulate and visualize the motion of equipment and tooling to more effectively develop and optimize manufacturing processes before committing to a manufacturing concept.

AutoCAD® Electrical provides a complete set of tools for controls design, and works in concert with Autodesk Inventor to integrate electrical controls into mechanical equipment and tooling designs. In addition, the cable harness routing capability of Inventor automates the process of integrating electrical controls.

The Autodesk® Moldflow family of products provides powerful simulation capabilities to simulate the complete process for injection molded components, enabling the optimization of tooling designs and manufacturing processes before the first part is ever molded.

Autodesk enhances internal and external collaboration by better sharing and managing design data with products like Autodesk® Vault and Autodesk Design Review. Autodesk Vault enables the effective reuse of product design data and the ability to leverage prior design analyses, freeing design teams to focus on true product innovation. Autodesk Design Review software is the most widely used design review and markup software in the world with over 20 million downloads to date.

Autodesk® NavisWorks® enables the integration of building, product, equipment, and other data to create a complete digital model of the factory. NavisWorks provides facility and manufacturing engineers a whole project view for improving design decision-making, construction implementation, and performance prediction and planning, straight through to management and operation of the facility.





Image courtesy of Ulysee Nardin

### Sales & Marketing

In a highly competitive market, brand loyalty is critical to profitably growing revenues. Consumer product manufacturers want consumers to connect with their products. That's why marketing is a crucial part of the new product development process. It involves gathering input from the marketplace on what consumers want and producing high-quality promotional material for consumer products. Being able to quickly get feedback from focus groups becomes a competitive advantage for your company. And when your marketers can get early access to digital assets, they can gain time and make the new product launch process go more smoothly.

The Autodesk solution for Digital Prototyping can help you engage consumers with your new products:

- **Interactive product experience**—Building customer relationships and strengthening brand loyalty by taking advantage of digital models to create compelling interactive experiences for consumers.
- **Focus group feedback**—Using digital prototypes to quickly produce new product iterations and test consumer opinions more cost-effectively.
- **Collateral development**—Leveraging digital assets, even before production has started, to create a broad range of marketing collateral for new product, including brochures, advertisements, presentations, video, and online material.



Image courtesy of Tine Latein

Autodesk provides solutions for virtual photography and cinematography that enable marketing teams and creative agencies to market products without the need for costly physical prototypes and photography shoots. These tools effectively repurpose the digital prototype and allow the development of marketing materials in parallel with product development.

Autodesk® Showcase® provides advanced visualization of the digital prototype combined with ease of use. Finished products can be visualized in a virtual photo studio setting or a custom environment, to communicate design intent to the customer with photorealistic quality.

For additional visualization, Autodesk® 3ds Max® Design software leverages Autodesk Inventor engineering data to create advanced visualizations of digital prototypes which can incorporate additional modeling, effects, and animations.



### Customer References

“3D digital prototypes are very easy to interpret. Inventor models facilitate instant and clear communication—even between teams that speak different languages.”

—Phil Eichmiller  
Industrial and Mechanical Designer  
Rodin



“We have chosen the right products from the Autodesk Digital Prototyping product portfolio. With them, we create 3D CAD models, high-end visualizations and animations, simulation results, and rapid prototyping models.”

—Christian Sperka  
CIO  
Franke



“By embracing Autodesk Inventor and using it to create digital prototypes, we were able to take the development timeline from roughly 18 months to 9 months. In addition to the time savings, there's a tremendous amount of money saved and benefits to be gained just simply getting to market sooner.”

—Jason Faircloth  
Product Manager  
Marin Bikes



“There is tremendous competition in the golf club industry with rates of new product introductions accelerating, and breadth of product lines increasing. Design has become the key competitive advantage and our team of experts armed with Alias are helping us lead the way.”

—Alan Hocknell  
VP Innovation and Advanced Design  
Callaway Golf Company



“Autodesk Inventor helps us check the product quality of a new design before it ever hits the manufacturing floor. As a result, we're able to bring products to market much faster than our competitors can.”

—Darin Janoschka  
Director of Product Development  
Flo Healthcare



“Autodesk Alias allows us to control complex surfaces better than anything else out there. With it we can address the true subtleties of product design.”

—Brett Lovelady  
President  
Astro Studios



“We've been using Autodesk Alias for over ten years. Without Autodesk, I don't know how we'd do it.”

—Ravi Sawhney  
CEO and President  
RKS Guitars





### Autodesk® Alias Design

Autodesk® Alias Surface (previously known as Autodesk AliasStudio®) modeling software provides all the tools you need to create Class A quality surface models – faster.



### Autodesk SketchBook Pro

Autodesk® SketchBook® Pro is designed specifically for use with digitized pen tablets and tablet PCs. Industrial designers can capture ideas without switching from pen to keyboard and back again.

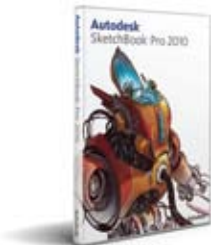

### Autodesk Showcase

Autodesk® Showcase® software enables transportation designers to transform 3D CAD data into visually realistic images for interactive to support design and customer reviews.



### Autodesk Design Review

Accelerate automotive reviews with Autodesk® Design Review software, the all-digital way to view, mark up, and track changes to 2D and 3D CAD designs without the original creation software.



### Autodesk Vault

Autodesk® Vault, previously known as Autodesk® Productstream®, securely stores and manages engineering information, design data and documents.



### Autodesk Navisworks

Autodesk® Navisworks® manufacturing software offers a comprehensive set of 3D digital mockup tools for large-scale assembly visualization and analysis, multi-CAD data aggregation, and collaboration.



### Autodesk Moldflow

Autodesk® Moldflow® is a comprehensive suite of injection molding simulation tools used to analyze and optimize the creation of molder parts and their associated molds.



### AutoCAD

AutoCAD helps transportation equipment manufacturers speed documentation and share ideas seamlessly with its powerful, flexible features for both 2D and 3D development.



### AutoCAD Electrical

AutoCAD® Electrical is AutoCAD® software for controls designers, purpose-built to create and modify electrical control systems.



### AutoCAD Mechanical

AutoCAD® Mechanical is AutoCAD for manufacturing, purpose-built to accelerate the mechanical design process while preserving the AutoCAD user experience.



### Autodesk Inventor

The foundation for Digital Prototyping, Autodesk® Inventor® software provides a flexible set of software for 3D mechanical design, simulation, tooling creation and design communication for transportation equipment manufacturers



